

# Technical Manual

Installation Guideline for Small Wind Turbines



**BUNDU  
POWER**

[www.hybridpower.co.za](http://www.hybridpower.co.za)

**011 397 7373**

Kilowatt Park  
2 Bravo Road  
Jetpark  
Johannesburg

# Table of Content

1. Safety Considerations.....	3
1.1 Mechanical Safety.....	3
1.2 Electrical Safety.....	3
1.3 Installation Hazards.....	3
1.4 Operational Safety.....	3
2. Wind Turbine Overview	
2.1 Turbine Description.....	4
2.2 Applications and uses.....	6
2.3 Regulators and Inverters.....	6
3. Site Considerations and Mountings.....	8
3.1 Roof Mounting.....	8
3.2 Mounting Structures and Poles/Towers.....	8
3.3 Standard Tower (Guyed).....	9
3.4 Standard Tower Scissor.....	9
4. Regulators for Wind Turbines.....	9
4.1 Dump Regulator.....	9
4.2 Shunt Regulator.....	9
4.3 Adjusting and Charging Voltage.....	11
4.4 TriStar Regulator.....	11
5. Cable Sizing.....	12
5.1 Lighting Protection.....	12
5.2 Outdoor Wire Table.....	12
6. Battery Considerations.....	13
6.1 Lead Acid Batteries.....	13
6.2 Sealed Gel Batteries.....	13
6.3 Ni-cad Batteries.....	14
6.4 Temperature Compensation.....	14
7. Technical Specifications.....	14
8. Trouble Shooting.....	15
9. Maintenance.....	16

## 1. SAFETY FIRST

Wind Turbines are designed with your safety in mind, accidents can easily occur and there are always inherent dangers associated with any type of machine. **Consult installation professionals if you lack experience or confidence.**

### 1.1 Mechanical Safety

Use good handling methods and take precautions to avoid physical injury during installation and maintenance/repair procedure. The rotating blades of any wind turbine are a main hazard. The Wind Turbine blades are extremely tough and will cause serious injury to the body. **Never install the wind turbine such that any person or animal could come into accidental contact with any part of the machine. Never approach the machine if the blades are rotating.**

### 1.2 Electrical Safety

Wind Turbine output voltage can become dangerous and even lethal when Running on open circuit. Maintain a healthy respect for this wind turbine. **Always short the output wires together and when the turbine is running or when lightning is present. Do not work on the system when the turbine is running or when lightning is present.** Disconnecting a running turbine may cause a spark and the presence of explosive hydrogen from battery is always a possibility. **Adequate ventilation must be provided for battery installation.** The wire size used for connections must be correct for the powers supplied. The smaller the wire diameter, the higher the wire losses and therefore the heat generated in the wire. **Use correct wire sizes throughout the installations.** The amount of energy stored in a battery is considerable and fire can result from shorts. **Fit a suitable fuse or circuit breaker in the battery cable.**

**In general, respect the system and use common sense. Consult a qualified electrician if you are unsure.**

### 1.3 Installation Hazards

**All installation work should be completed at ground level wherever possible.** Be very aware of the blades during installation. Contact with the blades will only injure you, not the blades. The installations of poles or towers pose their own dangers. **Always work carefully and have an assistant wherever possible. Short the generator output wires (Red and Black) throughout any installation procedure and during any maintenance.** Consult a civil engineer or reputable builder if you are not sure about installing structures. Always re-check the work as you progress. Slack bolts, poor workmanship and loose electrical connections must be avoided.

### 1.4 Operational Safety

The turbine blades are dangerous. **Respect a rotating turbine.** Always shut the turbine down before approaching. This may be achieved by shorting the generator output. **A regular visual check of all system parts is recommended. Preventative maintenance is always the best.** Checks are best carried out in calm weather conditions. Avoid any maintenance or inspections during windy weather.

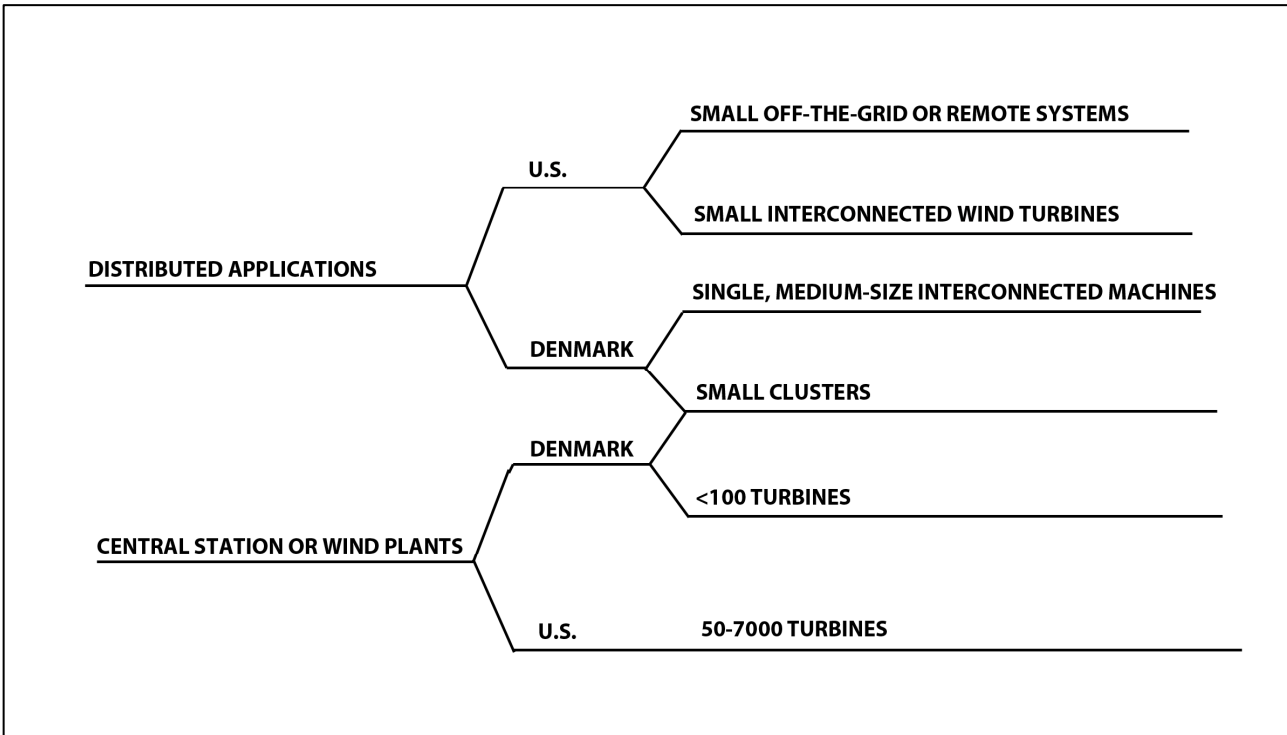

**Models of Wind development:** Europeans have followed a different path than the Americans in the development of wind energy. Most commercial wind turbines in North Europe are installed in small clusters, compared to the massive wind farms found in North America.

## 2. WIND TURBINE OVERVIEW

### 2.1 Turbine Description

The wind turbine incorporates superior technology. The heart of the machine comprises of a single axial flux permanent magnet brushless alternator. The alternator contains no less than 48 poles and 26 magnets. The polyphase high frequency output is internally rectified to give a dc output with extremely low ripple content. The generated power is transferred to the output cables via heavy duty bronze slip rings and twin copper composite electrical brushes. The prime mover on the turbine is a 1, 5m (5) diameter six blade wind rotor fitted with quiet running, high efficiency blades. The blade hub is fixed. The Turbine relies on motor turbulence and interference to achieve speed control.

The tail vane assembly is static and simply aligns the machine with the prevailing wind.

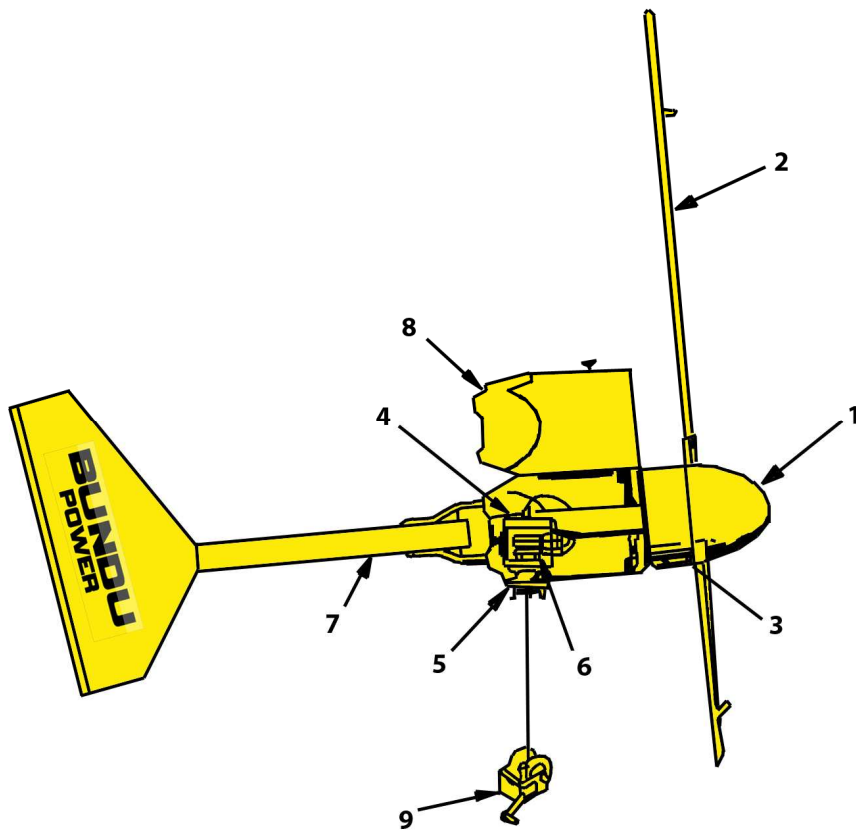

**Small Wind Turbine:**

1. Spinner or Nose
2. Rotor Blades
3. Direct-Drive Alternator
4. Mainframe
5. Yaw Assembly
6. Slip rings and brushes
7. Tail Vane
8. Nacelle Cover
9. Winch for furling the rotor out of the wind. (Bergey Wind Power)

**Medium-size Wind Turbine:**

Typical first generation (55-75kW) Danish wind turbine. Note that even in such early designs; provisions were made to safely service the turbine by the inclusion of a fall-arresting system (on the ladder inside the tower) and the work platform of the nacelle.

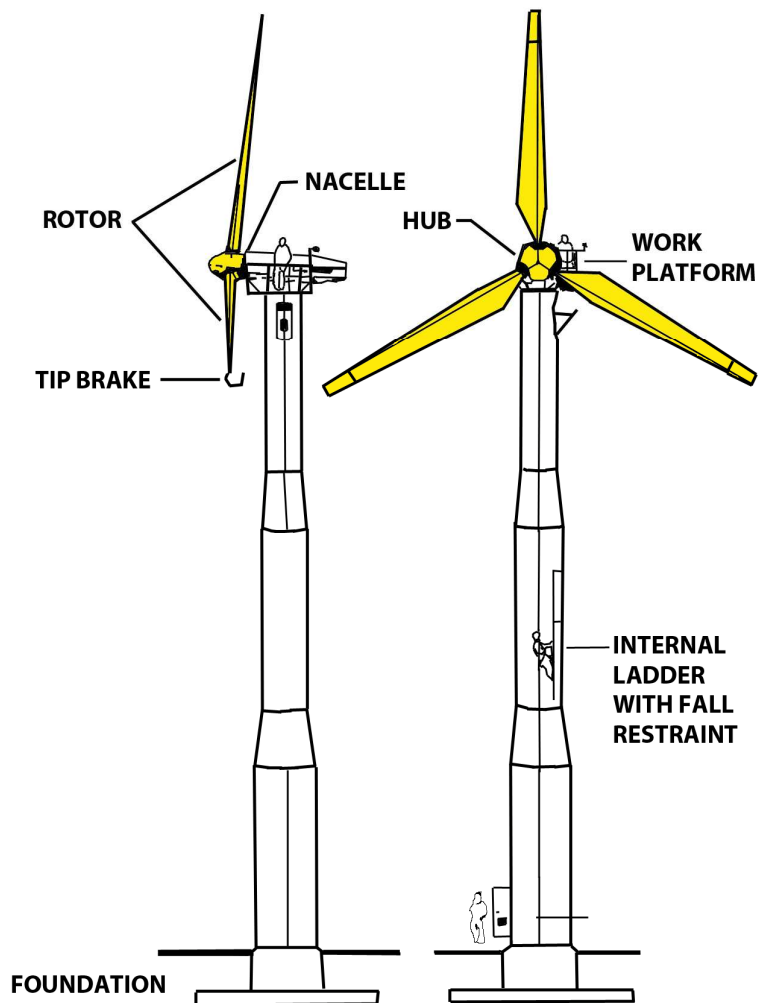

## **2.2 Uses and Applications**

The turbine is suitable for battery charging, water pumping and delivery, and grid connected installations.

## **2.3 Regulators and Inverters**

Any wind turbine produces uncontrolled power that varies with the incident wind speed. The open circuit generator voltage is directly proportional to generator speed (rpm). Some form of regulator must control this "raw power"

The charge controller uses electronic means to regulate the incoming power and apply the correct charging voltage to the installed battery.

## **3. SITE CONSIDERATION AND MOUNTING**

There are infinite variation on sites and the information and suggestions may be adapted to suit local conditions. Wind speed increases with height above ground. An installation site should be chosen which is free of obstructions like buildings, trees, mounds and hills. A 'pure' airflow is paramount for good performance. Naturally some compromise can be reached but there should be a clear entry for the prevailing wind direction of the location. The absolute minimum height of the structure should be 6m when placed clear of obstructions.

The general rule is that the turbine should be 8m (25) higher than any obstruction within a 150m (500) radius of the tower, otherwise mount the turbine as high as possible. All obstructions add to the possible turbulence, which will cause undue stress on the unit and reduced performance. Wind speed increases with height above ground. The power in the wind is a cubic function of wind speed. Doubling the wind speed increase the power by eight times.

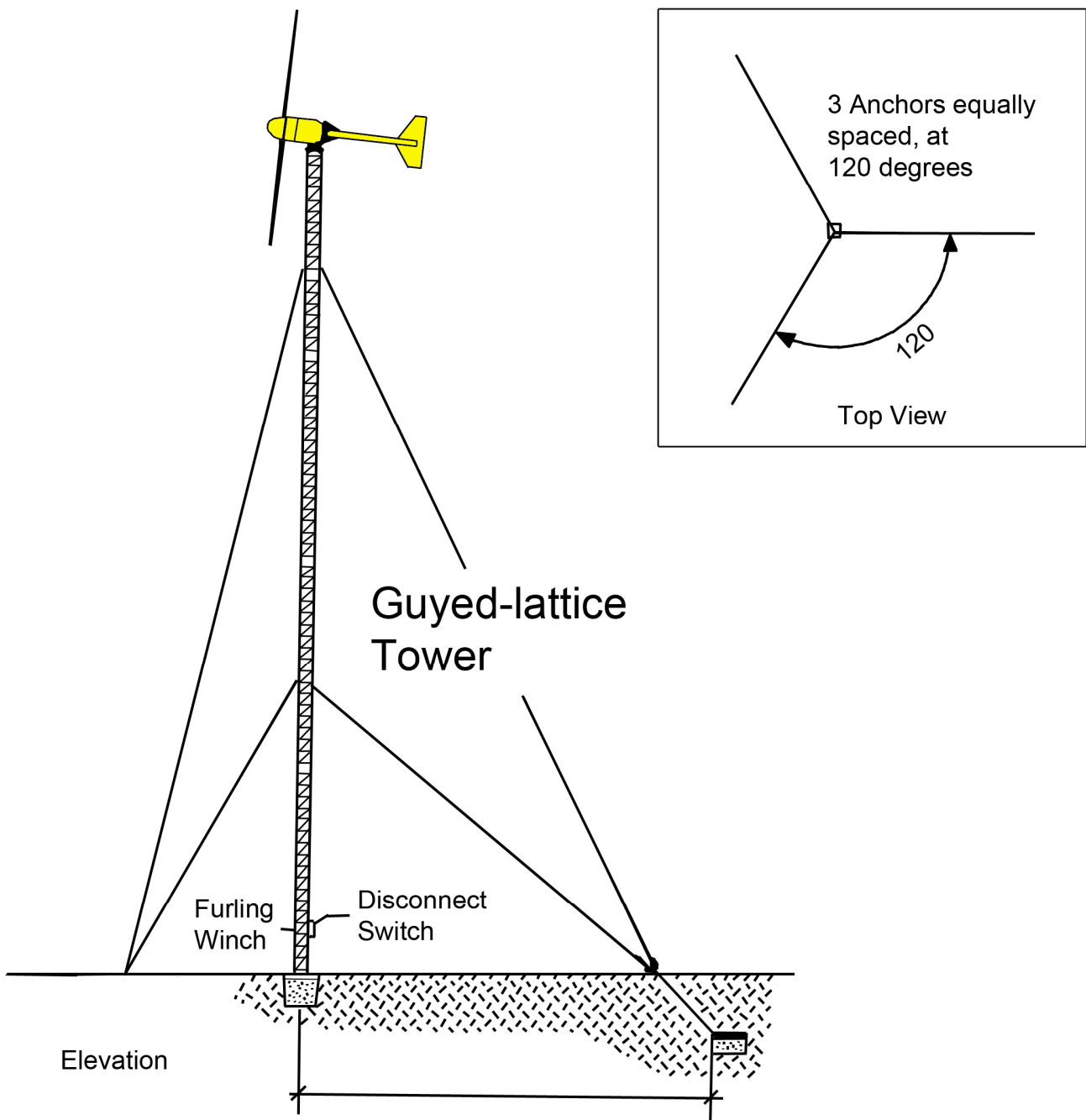

**Guyed Lattice mast:** A typical guyed tower of household size wind turbine in North America. (Bergey Windpower)

### 3.1 Roof Mounting

The site of the turbine is all important. Roof installations are quite possible and not recommended. Beware of possible transmission of noise into the building, turbulence created by various roof shapes and possible damage to the roof in high winds. Roof mounted turbines are usually supported by a structure that is attached to the outside wall of the building and not the actual roof.



**Micro Wind Turbine:** Micro wind turbine shown here on a cottage uses a 5 blade rotor slightly less than 1 meter in diameter and is capable of 0.05kW.

### 3.2 Mounting Structures and Poles

Many structures are possible and should be designed to withstand up to 600N (60kg mass) of lateral thrust at the tower top. A single pole constructed from water pipe or scaffold tube with three or four guys will often be satisfactory. Note that the guys are unsuitable where animals graze as they habitually rub against the wires and loosen the ground anchors over time.

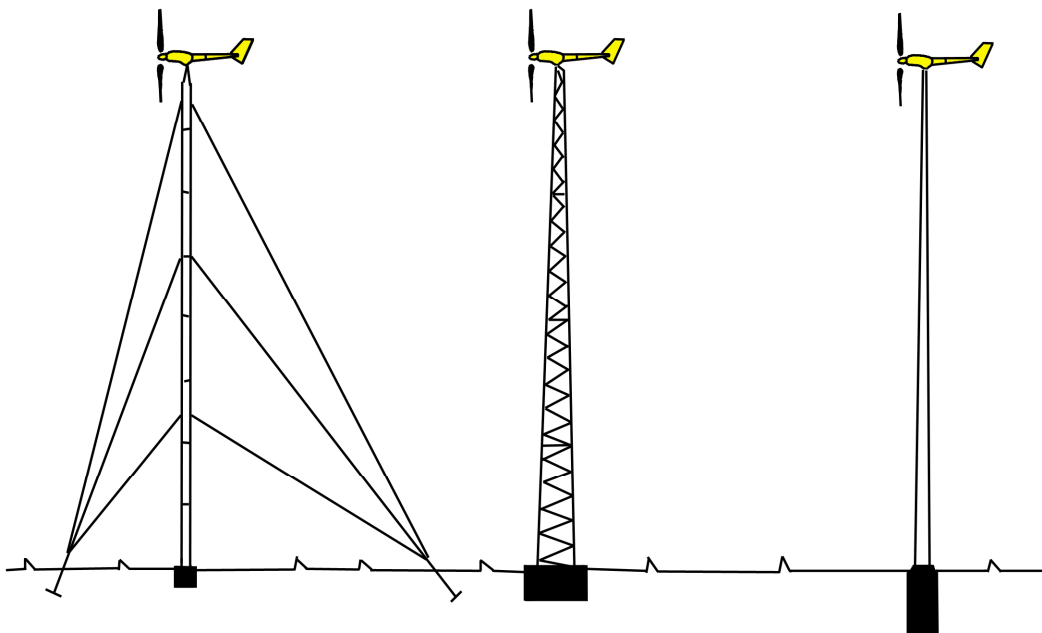

**Tower Types:** For small turbines, guyed towers (left) are the most economical. Freestanding lattice (center) and cantilevered tubular towers (right) are more costly but are also options.

### **3.3 Standard Tower (Guyed)**

A standard, affordable tower kit is available. The kit includes most of the components required to construct a guyed tower. The only additional parts required are two 6m lengths of pole and four ground anchors. A 6m (20) tower is possible with one length of pole and other heights up to 13m (40) can be constructed.

### **3.4 Standard Tower Scissor**

The scissor tower gives good operator safety as all work is carried out at ground level. The tower is free standing and can swing down. The system is balanced for simple operation. The scissor tower is manufactured for three hub heights'. 9m (30), 12m (40) and 15m (50).

## **4. REGULATORS**

There are regulators which are specifically designed to operate with wind generator. Do not connect photovoltaics to the wind turbine regulator. This may well overload the regulator in extreme weather conditions.

**NEVER OPERATE A DUMP REGULATOR WITH NO BATTERY CONNECTED!!!!!!**

**It is strongly advised to fit an external circuit breaker or fuse in the battery charging line. Use the following ratings: 100A for 12V, 40A for 24V dc, and 30A for 48V dc.**

### **BATTERY CHARGING**

Charge regulators are highly efficient and only operate after the battery being charged reaches float voltage. Thereafter any unwanted energy is converted into heat. The system is totally electronic and there are no contacts to burn out. If the regulator is continually hot, increase the Ah rating by adding another battery to store the additional energy or use more free electricity.

There is no fuse mechanism fitted for the turbine. It is however strongly recommended that a battery fuse or circuit breaker be fitted close to the battery. This breaker will protect all wiring in the event of a short or fault at the turbine.

### **4.1 Dump Regulator (General Application)**

This regulator is more suitable for general charging applications. The Turbine continually supplies the load and battery until the battery voltage reaches the float level. The regulator then transfers the power from the battery to a dump resistor. As the voltage falls on the battery, the regulator transfers power from the resistor back on to the battery. The cycle then repeats.

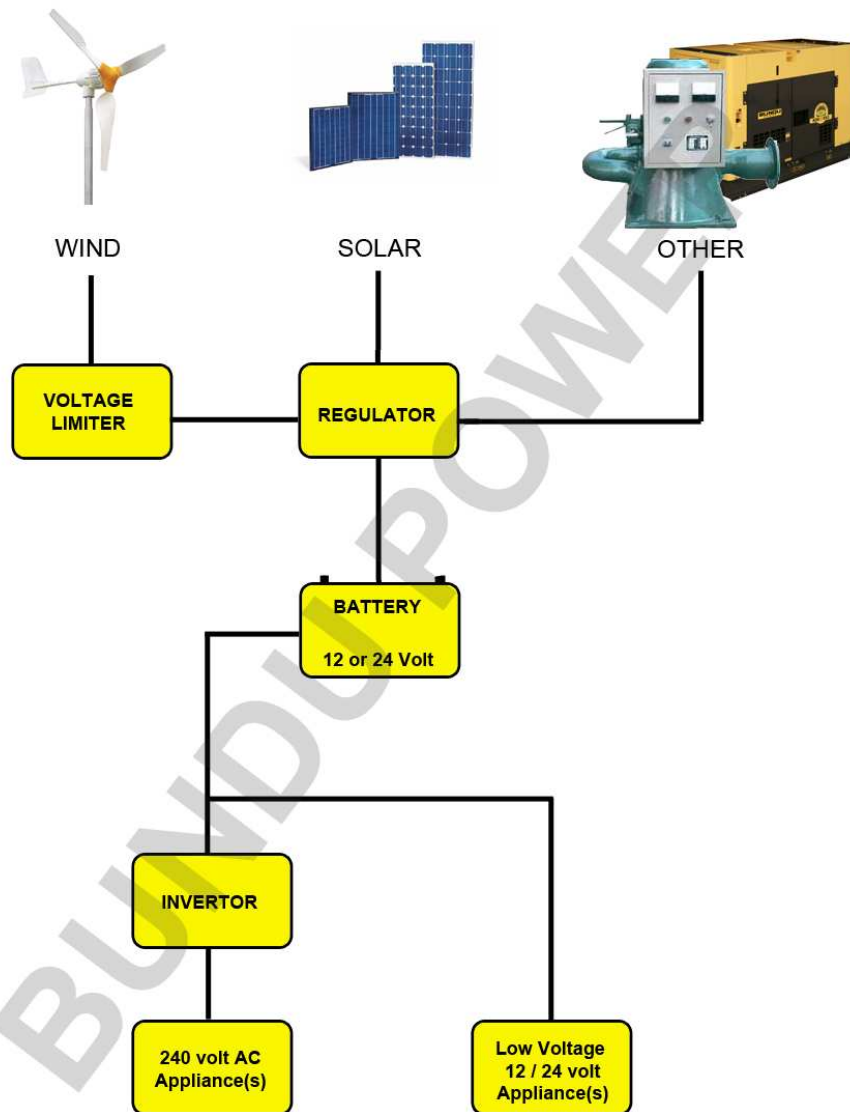

### WIRING

Observe the Polarity at all times. Only connect **+VE RED** cables to **+VE RED** terminals and **-VE BLACK** cables to **-VE BLACK** terminals. Otherwise equipment may be damaged.

The dump regulator is provided with two pairs of +VE and –VE clearly marked terminals for “Turbine” and “Battery” at the bottom of the regulator. If a turbine brake switch is not fitted then the turbine wires are shorted during installation. The reason is simply to break the turbine and prevent high turbine open circuit voltages being developed.

- (a) Arrange the wires from the turbine and the battery ready for connection.
- (b) Check that the turbine wires are shorted. Check that the battery wires are disconnected from the battery or breaker is off, or the battery fuse is removed.
- (c) Connect the battery wires to the dump regulator battery terminals observing polarity.
- (d) Connect or switch on the battery to the regulator. The dump regulator is now operational with battery power.
- (e) Separate the turbine wires and connect the turbine negative wire to the dump regulator turbine negative terminal. You may have to improvise by maintaining a short on the turbine wires as this connection is made
- (f) Finally connect the turbine positive wire to the dump regulator turbine positive terminal.

THE INSTRUCTIONS ARE REVERSED FOR DE-COMMISSIONING. FIRST DISCONNECT THE TURBINE WIRES AND THEN THE BATTERY CONNECTIONS. A DISCONNECTED TURBINE SHOULD ALWAYS BE SHORTED.

### 4.3 Adjusting the Charging Voltage

The dump regulators are suitable for all lead acid batteries whether vented, semi-sealed or sealed and the charging voltage may be adjusted. When the cover is removed the jumper is visible in the middle of the control board. The charging voltage may be adjusted to the following table.

There are five positions for the jumper. The value is the charging cell voltage. The derived charging voltages are given in the table below. Consult your battery supplier for the correct charging voltage.

**Charging voltages for 12V system**

-	-	<b>2,366</b>	<b>14,2V</b>
-	-	<b>2,350</b>	<b>14,1V</b>
-	-	<b>2,333</b>	<b>14,0V</b>
-	-	<b>2,315</b>	<b>13,9V</b>
-	-	<b>2,300</b>	<b>13,8V</b>

**Charging voltage of a 24V system**

-	-	<b>2,366</b>	<b>28,4V</b>
-	-	<b>2,350</b>	<b>28,2V</b>
-	-	<b>2,333</b>	<b>28,0V</b>
-	-	<b>2,315</b>	<b>27,8V</b>
-	-	<b>2,300</b>	<b>27,6V</b>

**Charging voltages for 48system**

-	-	<b>2,366</b>	<b>56,8V</b>
-	-	<b>2,350</b>	<b>56,4V</b>
-	-	<b>2,333</b>	<b>56,0V</b>
-	-	<b>2,315</b>	<b>55,6V</b>
-	-	<b>2,300</b>	<b>55,2V</b>

### 4.4 Hybrid Tri Star

The Hybrid Tri Star charging regulator is suitable for use with wind turbines. The regulators use a different method of control. Charging sources, for example wind solar hydro and diesel backup all connect directly (via circuit breakers) to the storage battery. The regulator also connects straight to the same battery. When energy production exceeds the combined battery and load requirement the regulator diverts this excess energy to a load resistor.

The regulator has a maximum current rating that must not be exceeded. A 600W turbine 48VDC turbine will produce a maximum current of 25A. The regulator is designed for a maximum current of 30A in divert mode and is suitable. A 600W Turbine 24Vdc turbine will produce a maximum current of 40A. The regulator is designed for a maximum current of 45A in divert mode and is suitable.

The regulator must be programmed to operate in the DIVERT mode. A suitable divert resistor is available. The resistive value is different for 24Vdc and 48Cdc. Consult your dealer for more information.

## 5. WIRE AND CABLE SIZE

The following suggestions are made as a guideline. If you are in doubt, consult an electrician.

All electrical system loses energy because cables have a resistance. The mounting structure must be directly earthed for lightning. The power cable is usually brought down the inside of the mounting structure to give some protection. Supply cables should never be spanned or suspended from the turbine structure and should be buried at least one half metre deep in a suitable plastic or steel conduit.

### 5.1 Lightning Protection

Proper grounding is essential to protect the system from induced voltages and static. Local requirements for electrical installation must be satisfied. Ensure that the generator is electrically connected to the mounting structure and that the structure is earthed. This usually done by burying a 2- 3m (6' – 10') length of water pipe (steel or copper) horizontally, 800mm (2,5') below the ground surface. A good connection is made between the middle of the pipe and the structure. An improved method is to bury a cross of pipe, which requires an "X" shape to be excavated. The connection is made in the centre of the cross.

The negative battery connection should also be grounded using a ground point close to the battery. The wire size for grounding should be the same size as the power cables. Commercial lightning arrestors are available at electrical stores and can be fitted at the bottom of the structure or pole or at the regulator input.

### 5.2 Outdoor Wire Tables

**Be careful, most regulators for PV installation have got positive grounding. Please check with your supplier.**

The copper wire size given in the tables are calculated for 3% power loss in wire resistance. This is usually acceptable in low voltage installations. A larger wire size will increase the delivered power but usually a compromise is reached as larger cables cost more. It is recommended that the wire sizes given be taken as a minimum value.

Measure the distance from the top of your structure to the regulator. Select the wire size for that distance from the table. The double run of +ve and -ve is already accounted for.

The power cable should be run down the inside of the pole or structure and then buried in a suitable underground conduit at least 500mm below the ground surface.

**Wire size for 12V (60A maximum current)**

<b>10m (33')</b>	<b>20m (66')</b>	<b>30m (96')</b>
<b>35sq mm (2)</b>	<b>45sq mm (1)</b>	<b>85sq mm (000)</b>

**Wire size for 24V (32A maximum current)**

<b>10m (33')</b>	<b>20m (66')</b>	<b>30m (96')</b>	<b>40m(130")</b>	<b>50m (165')</b>
<b>16q mm (5)</b>	<b>35sq mm (2)</b>	<b>50sq mm (0)</b>	<b>70sq mm (00)</b>	<b>95sq mm (0000)</b>

**Wire size for 48V (19A maximum current)**

<b>m (33')</b>	<b>20m (66')</b>	<b>30m (96')</b>	<b>40m (130")</b>	<b>50m (165')</b>	<b>80m (260)</b>	<b>100m (330)</b>
<b>Sq mm (7)</b>	<b>20sq mm (4)</b>	<b>35sq mm (2)</b>	<b>35sq mm (1)</b>	<b>50sq mm (0)</b>	<b>70sq mm (00)</b>	<b>(100sq mm (0000)</b>

## 6. BATTERY CONSIDERATIONS

Batteries are available in many sizes, shapes and categories. In general only “Deep cycle” batteries and cells should be used and automotive and vehicle batteries will have a short life as they are not designed for cyclic charging and discharging. A cell is a single unit of 2V and a battery consists of a number of cells joined in series. The usual installation consists of 12V batteries arranged in a series or parallel or both. Batteries should not be exposed to temperature extremes and good ventilation is required as batteries can emit hydrogen while being charged.

The stored energy in a battery is given Ampere Hours (Ah) or Watt hours (Wh). The capacity is often based on a 10 hour discharge rate. A 100Ah battery will therefore supply a current of 5A for 20hrs or 10A for 10hrs or 20A for 5hrs. It will not however supply 100A of current for 1 hr. There is much literature available on this subject. It is recommended that the 600W turbine should be charging at least 200Ah of battery capacity for a 12V system.

### 6.1 Lead Acid Batteries

These are the most popular choice of battery type and can be vented/flooded (Water may be added) or semi-sealed or low maintenance (Water cannot be added). Charging voltage is typically 13,8 – 14,0 / 27,6 – 28,0 Vdc for these batteries.

### 6.2 Sealed Gel Batteries

Sealed Gel Batteries are more expensive but offer clean and safe operation as no acid can be spilled. Since they are sealed, they must never be boosted and the charging voltage is important. Charging voltage is typically 14,0 / 28,0V dc. Consult your battery supplier.

### 6.3 Ni-Cad Batteries

This type of battery is traditionally used where large currents must be delivered and where deep cycling is required. They are however relatively expensive. Consult your battery supplier for details.

### 6.4 Temperature Compensation

Much has been documented on this subject and there are certain merits. Generally lower and higher ambient temperatures allow lower and higher charging voltages respectively. The regulators do not have this facility. Batteries should be sited in a cool area and temperature compensation is only useful in extreme temperature variations.

## 7. TECHNICAL SPECIFICATIONS

600w TURBINE	
Rated Power (W)	600W
Max. Power (W)	650 from 14m/s
Alternator type	Axial flux
No. of poles	48
Generation steps	2
Rated w/speed	13m/s
Cut in w/speed	2.8m/s
Rotor diameter	1,5m (5')
No. of blades	6
Type of blade	Full aerofoil
Tower top mass	20kg
Lateral thrust	300N (12m/s)
Speed control	Rotor turbulence
Regulator	Shut or dump
Standard Vdc	12, 24, 48
Protection	IP55

Wind speed table		
m/s	Km/h	Mph
2.0	7.2	4.5
2.5	9.0	5.6
3.0	10.8	6.7
3.5	12.6	7.8
4.0	14.4	8.9
4.5	16.2	10.1
5.0	18.0	11.2
5.5	19.8	12.3
6.0	21.6	13.4
6.5	23.4	14.5
7.0	25.2	15.7
7.5	27.0	16.8
8.0	28.8	17.9
9.0	32.4	20.1
10.0	36.0	22.4
11.0	39.6	24.6
12.0	43.2	26.8
13.0	46.8	29.1

## 8. TROUBLE SHOOTING

PLEASE NOTE THAT THE TURBINE WILL BE SERIOUSLY DAMAGED FROM POLARITY REVERSAL. OVERCHARGING OF BATTERY CAN OCCUR WITH NO REGULATOR FITTED. IT IS UNWISE TO DISCONTINUE CHARGING BY DISCONNECTING THE TURBINE FROM THE BATTERY, THE TURBINE THEN HAS NO LOAD WHATSOEVER AND CAN REACH VERY HIGH ROTATIONAL SPEEDS.

**Uncontrolled output voltage can reach LETHAL values.**

IF THE TURBINE IS DISCONNECTED FOR ANY REASON, SHORT THE GENERATOR OUTPUT WIRES, THIS WILL LOAD THE GENERATOR AND MINIMISE ROTATION.

### DUMP REGULATOR

DO NOT UNDER ANY CIRCUMSTANCES ALLOW THE GENERATOR TO OPERATE WITH NO BATTERY CONNECTED TO THE DUMP REGULATOR. THE REGULATOR MAY BECOME INOPERATIVE.

DO NOT ALLOW THE TURBINE TO OPERATE WITH DAMAGED BLADES OR TAIL. DAMAGE TO THE BLADES WILL CAUSE VIBRATION THAT CAN INCREASE TO DESTRUCTIVE LEVELS.

- Q. - There is wind but the Turbine does not rotate or only rotates very slowly.
- A. - The turbine output is shorted. The regulator output is shorted. The blades are fitted the wrong way round. The regulator is defective (Disconnect the turbine from the regulator and check that the blades rotate easily). In very light wind, the turbine may well not rotate. This is quite normal as there is no useful power.
- Q. - The Turbine is vibrating or noisy.
- A. - Check all fasteners on the unit, in particular the blades assembly. Vibration or noise can only be caused by the imbalance of damaged blades. Check for bearing wear on older machines.
- Q. - The turbine is running and the green charging LED is on. The battery voltage is not charging.
- A. - Check any external battery fuses. Remove the fuse and replace with the correct value. The battery fuse will immediately fail if the battery is connected to the regulator with reverse polarity.
- Q. - Can the turbine be left running and disconnected?.
- A. - Theoretically yes, but high voltages may be produced. Always short the output wires when the Turbine is disconnected from the regulator.
- Q. - What should be done in storm conditions?
- A. - Never approach the Turbine during strong wind conditions. Some Turbines have been tested up to winds of 160km/ph and are designed to survive such conditions. It is acceptable to lower the turbine for predicted extreme weather conditions simply for peace of mind.

## 9. MAINTENANCE

A turbine is designed for continuous operation on 100% duty cycle and requires no regular part replacement. It is recommended that preventative maintenance checks be carried out every six months and after the occurrence of extreme weather.

### **NEVER APPROACH A ROTATING TURBINE**

- (a) Inspect the tower or pole including all bolts/fasteners ground anchors and guy wires.
- (b) Inspect the blades for any damage. Check the blade fixing bolts.
- (c) Inspect the turbine securing bolts.
- (d) Check the tail assembly and fixing bolts for damage. Replace if required
- (e) Wash the blades with clean water and soap.
- (f) Check the blades for any wear or erosion.
- (g) Check all electrical connections for tightness and corrosion.
- (h) Check that the passive pitch mechanism is functional.

Some Do's and Don'ts

Do plenty of research. It can save a lot of time, trouble and expense in the long run.

Do visit the library. Books remain amazing sources of information.

Do talk to others who use wind energy. You can learn a lot from them.

Equally important, after reading, FOLLOW the instructions.

Ask for help when you are not sure about something

Do build to code. In the end it makes for a tidier, safer and easier to service system.

Do take your time, there is no rush. The wind will always be there.

Do be careful. Wind turbines may look harmless, but they are not.

Don't skimp, and don't cut corners. Taking short-cuts is a sure-fire way to ruin an otherwise good installation.

Don't design your own tower – unless you are a licensed mechanical engineer.

Don't install your turbine on the roof, despite what some manufacturers may say.

And of course, don't believe everything you read in sales brochures, or on the internet. Get the facts and the right information.

## 1kW Wind Generator



### Technical Performance

MODEL	1kW Wind Generator
Rated power(W)	1000
Rotor Diameter (M)	2.8
Rated wind speed (M/S)	9
Startup wind speed (M/S)	3
Working wind speed (M/S)	3 - 25
Working voltage(V)	48V
Material and number of the blades	Reinforced fiber glass*3
Generator style	Three phase, permanent magnet
Speed regulation method	Tail furl
Stop method	Manual electronic brake / Automatic electric brake
Tower height (M)	6

Output Power Curve

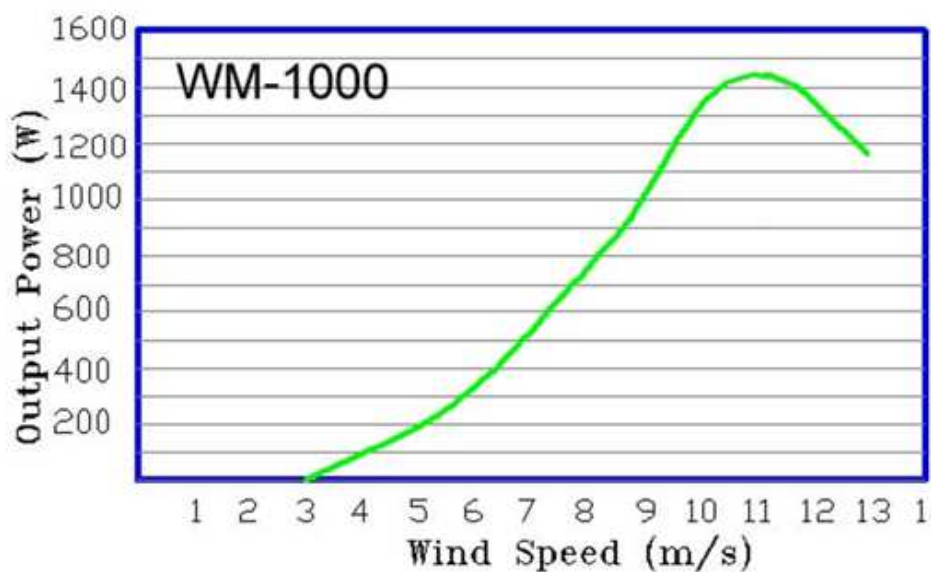

## 2kW Wind Generator



### Technical Performance

MODEL	2kW Wind Generator
Rated power(W)	2000
Rotor Diameter (M)	3.2
Rated wind speed (M/S)	9
Startup wind speed (M/S)	3
Working wind speed (M/S)	3 - 25
Working voltage(V)	48V
Material and number of the blades	Reinforced fiber glass*3
Generator style	Three phase, permanent magnet
Speed regulation method	Tail furl
Stop method	Manual electronic brake / Automatic electric brake
Tower height (M)	9

Output Power Curve

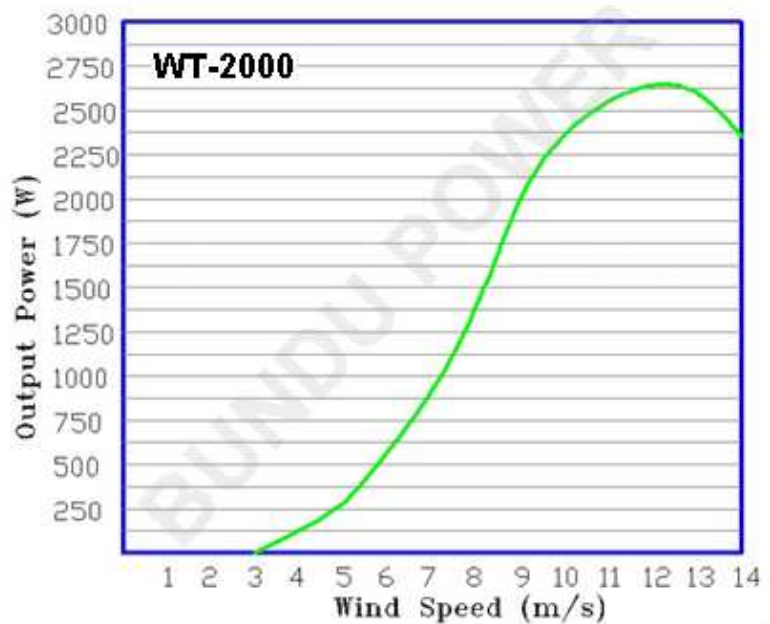

## 5kW Wind Generator



### Technical Performance

MODEL	5kW Wind Generator
Rated power(W)	5000
Rotor Diameter (M)	5
Rated wind speed (M/S)	10
Startup wind speed (M/S)	3
Working wind speed (M/S)	3 - 25
Working voltage(V)	48V
Material and number of the blades	Reinforced fiber glass*3
Generator style	Three phase, permanent magnet
Speed regulation method	Tail furl
Stop method	Manual electronic brake / Automatic electric brake
Tower height (M)	12

### Output Power Curve

